

Project title: Innovative lightweight cold-formed steel-concrete composite floor system

Acronym: LWT-FLOOR Project ID: UIP-2020-02-2964

1st LWT-FLOOR Workshop

Numerical Analysis of Lightweight Cold-Formed Steel-Concrete Composite Floor System

Andrea Rajić, Vlaho Žuvelek

andrea.rajic@grad.unizg.hr
vlaho.zuvelek@grad.unizg.hr

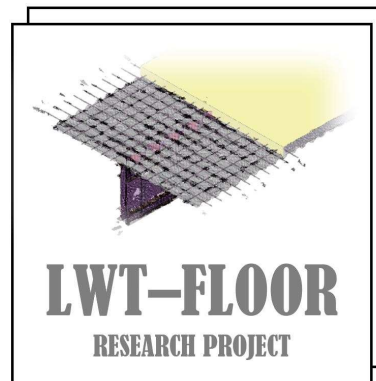

University of Zagreb/Faculty of Civil Engineering

<http://www.grad.unizg.hr/lwtfloor>

Steel-concrete composite beams

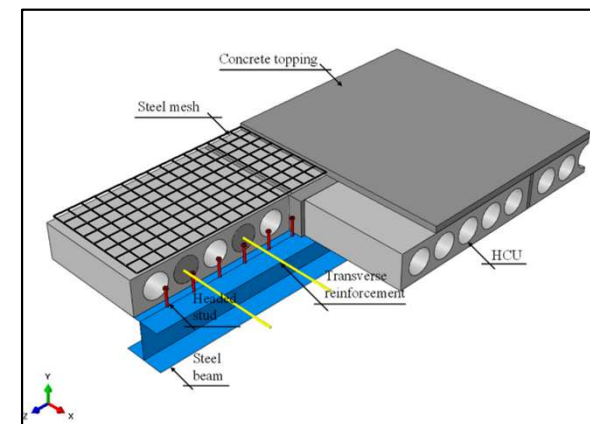
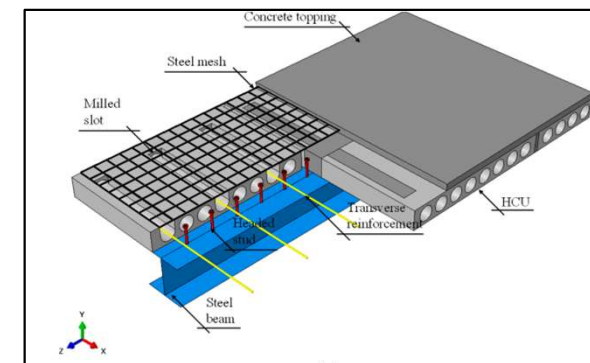
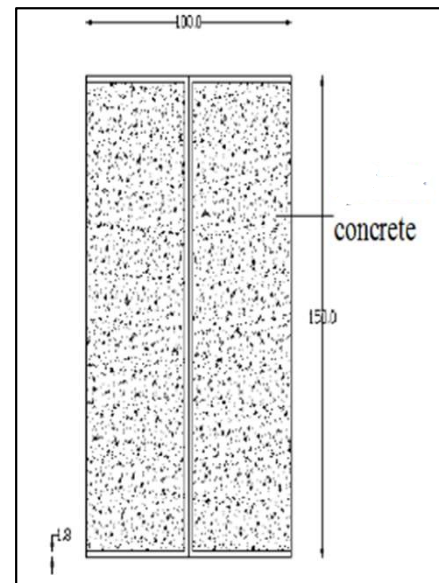
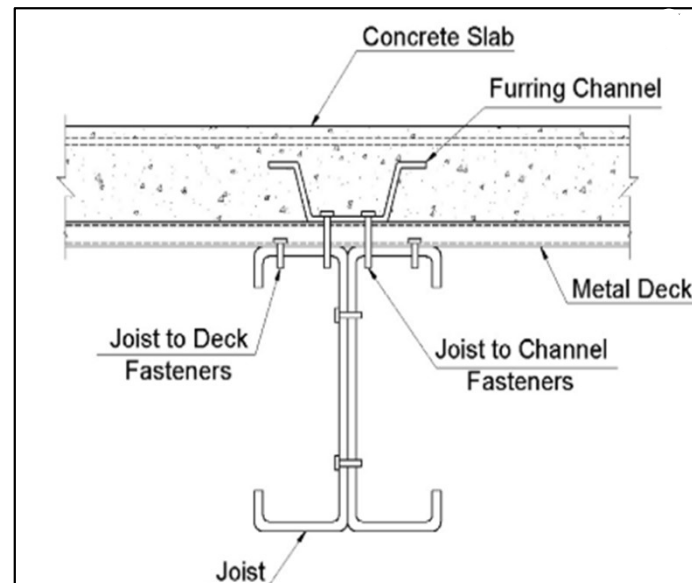
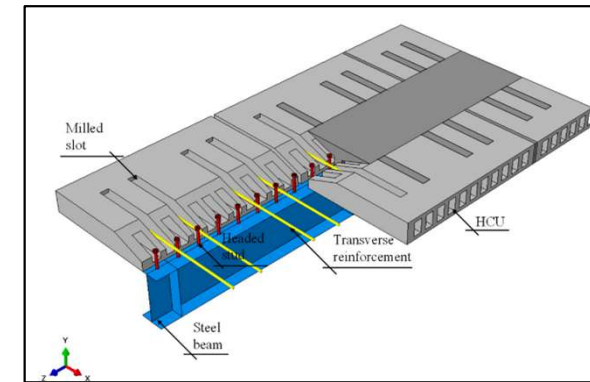
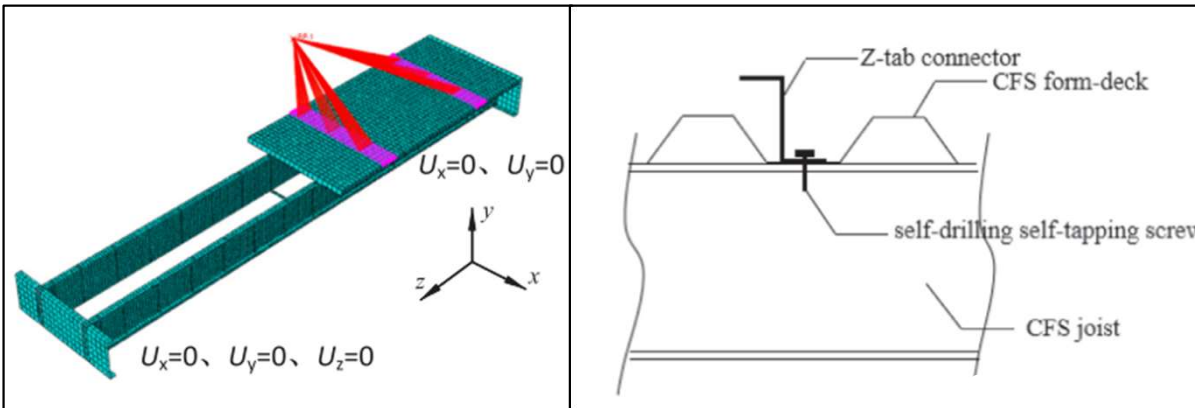

Analysed composite beam

STEEL

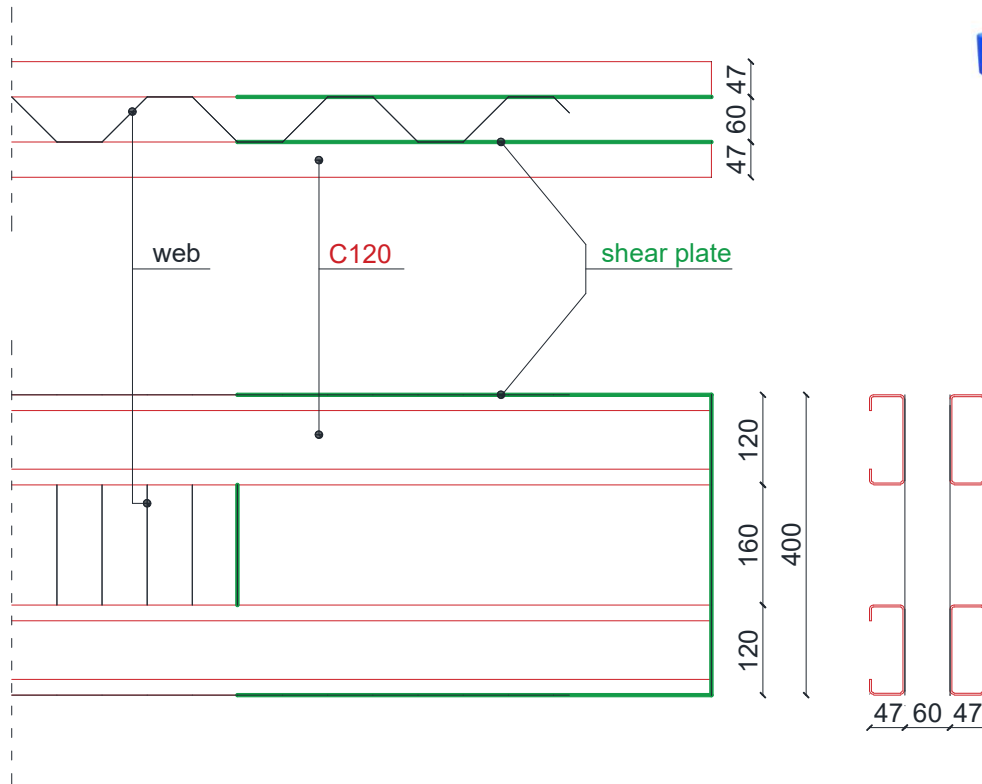

CONCRETE

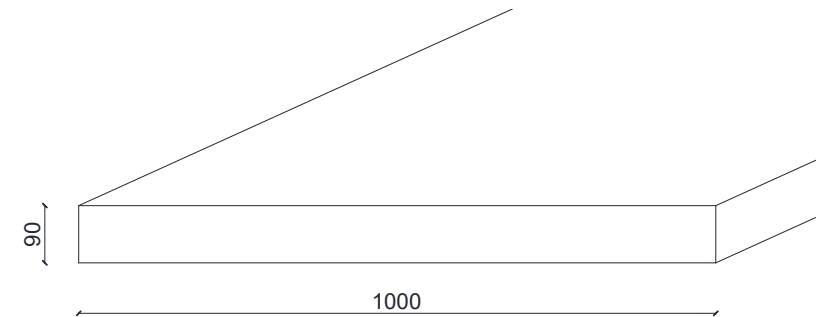

Numerical models

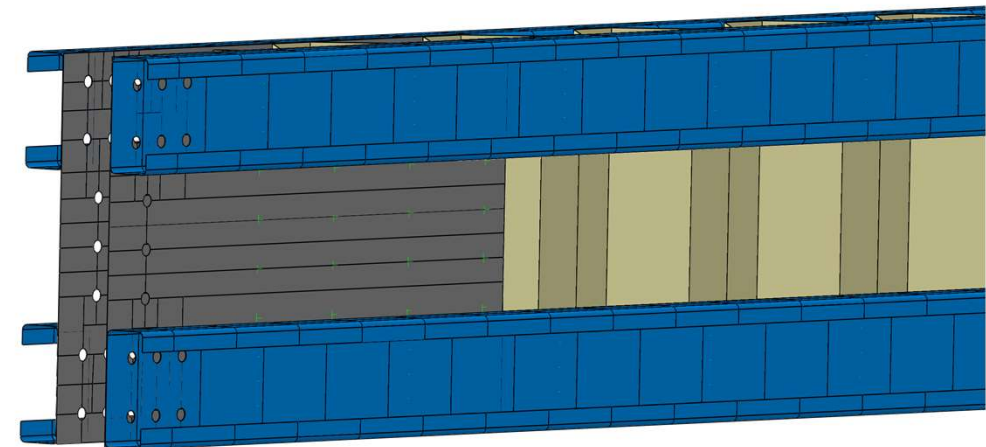
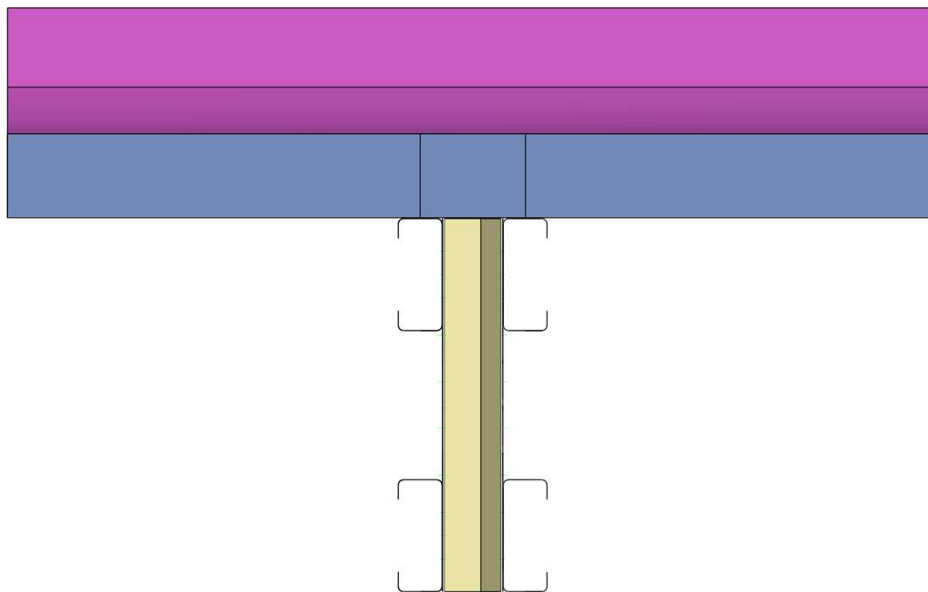
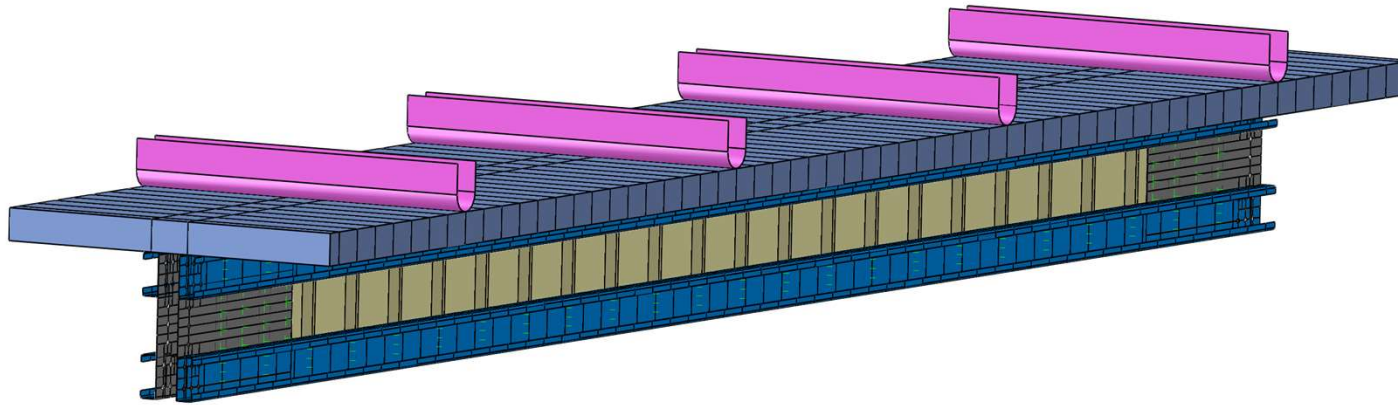

DS SIMULIA
ABAQUS

Numerical models

- FE mesh density:
 - Steel section: 10 mm
 - Loadings: 20 mm
 - Concrete slab: 30 mm
- Element type:
 - Steel section: S4R
 - Loadings: S4R
 - Concrete slab: C3D8R

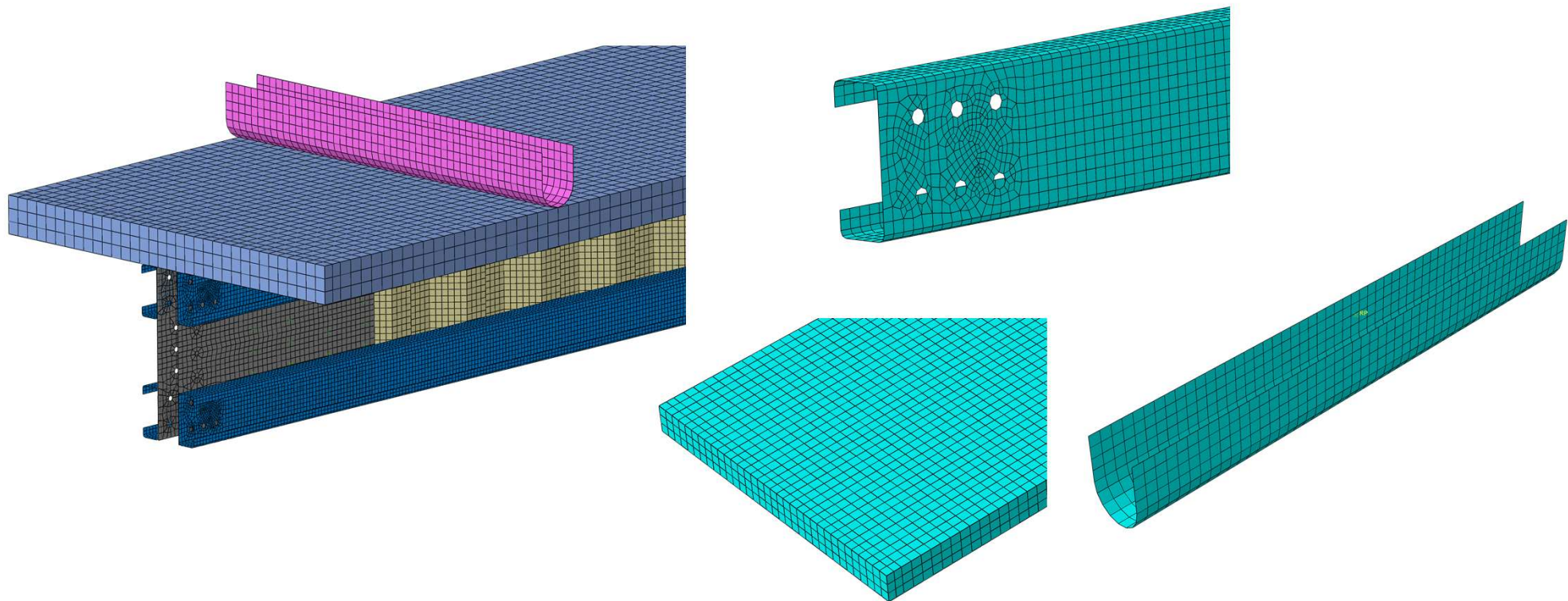

Connection between elements

TIE

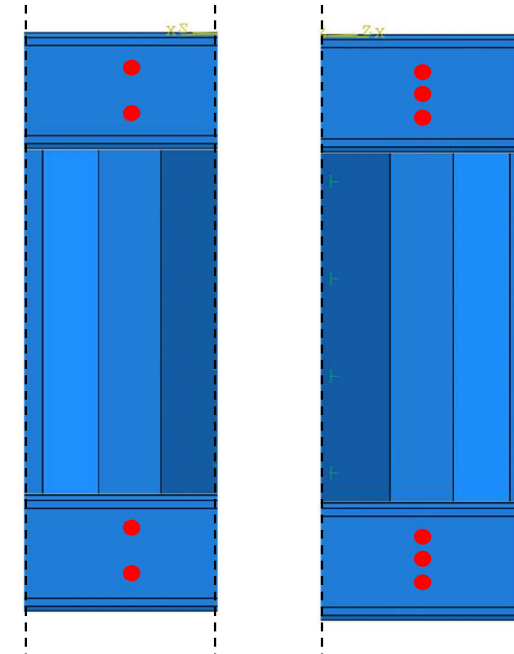
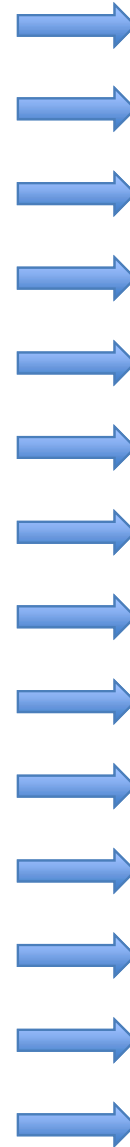
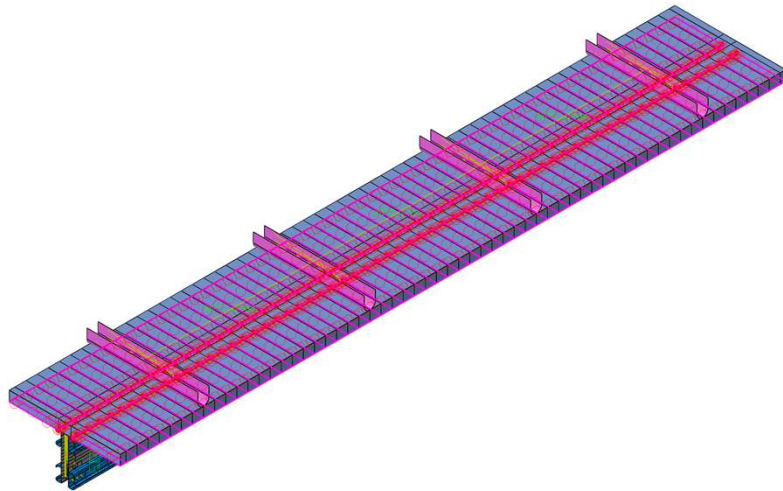

Connection between elements

PARTIAL SHEAR CONNECTION – 300 mm

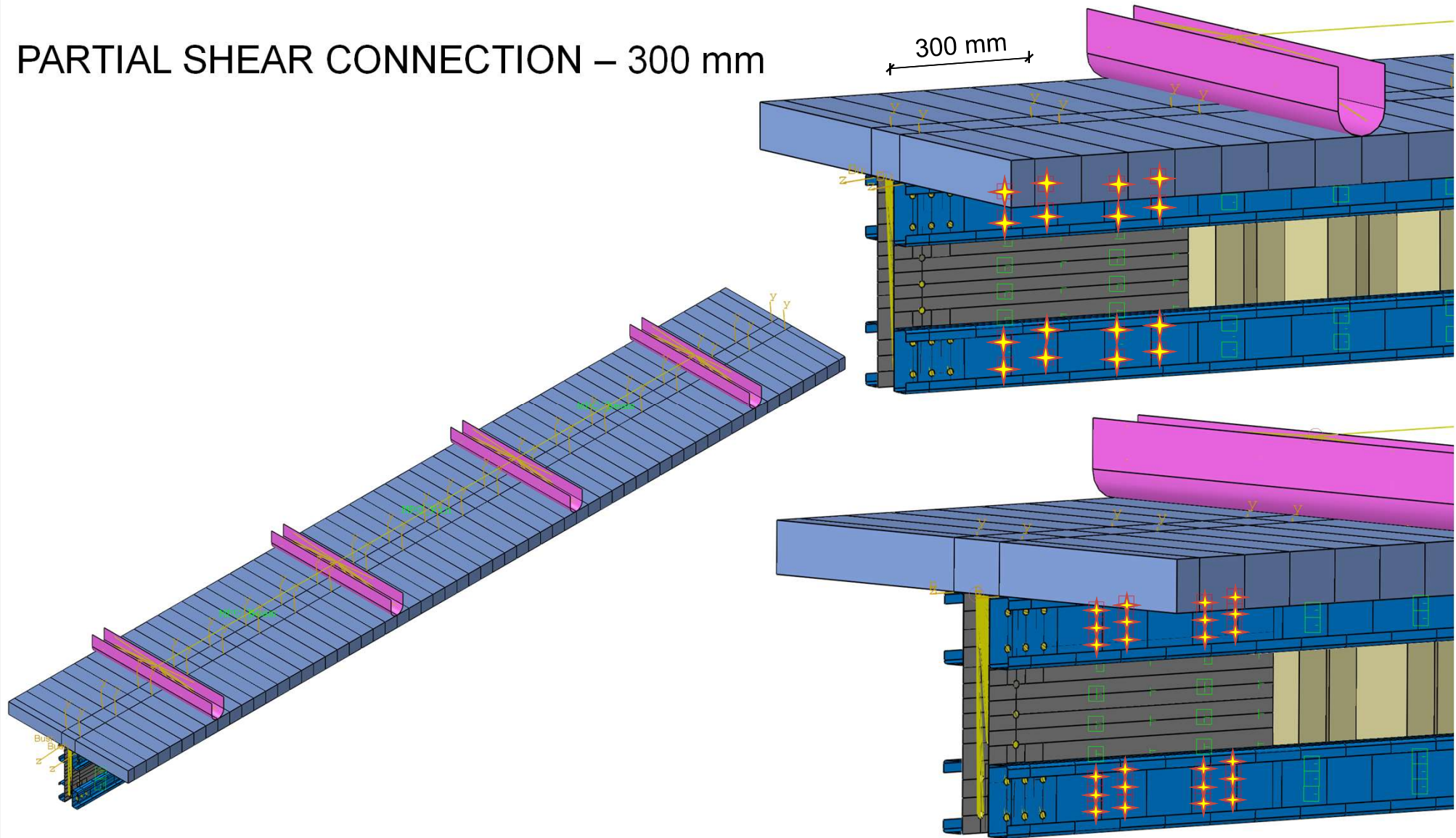

Connection between elements

PARTIAL SHEAR CONNECTION – 600 mm

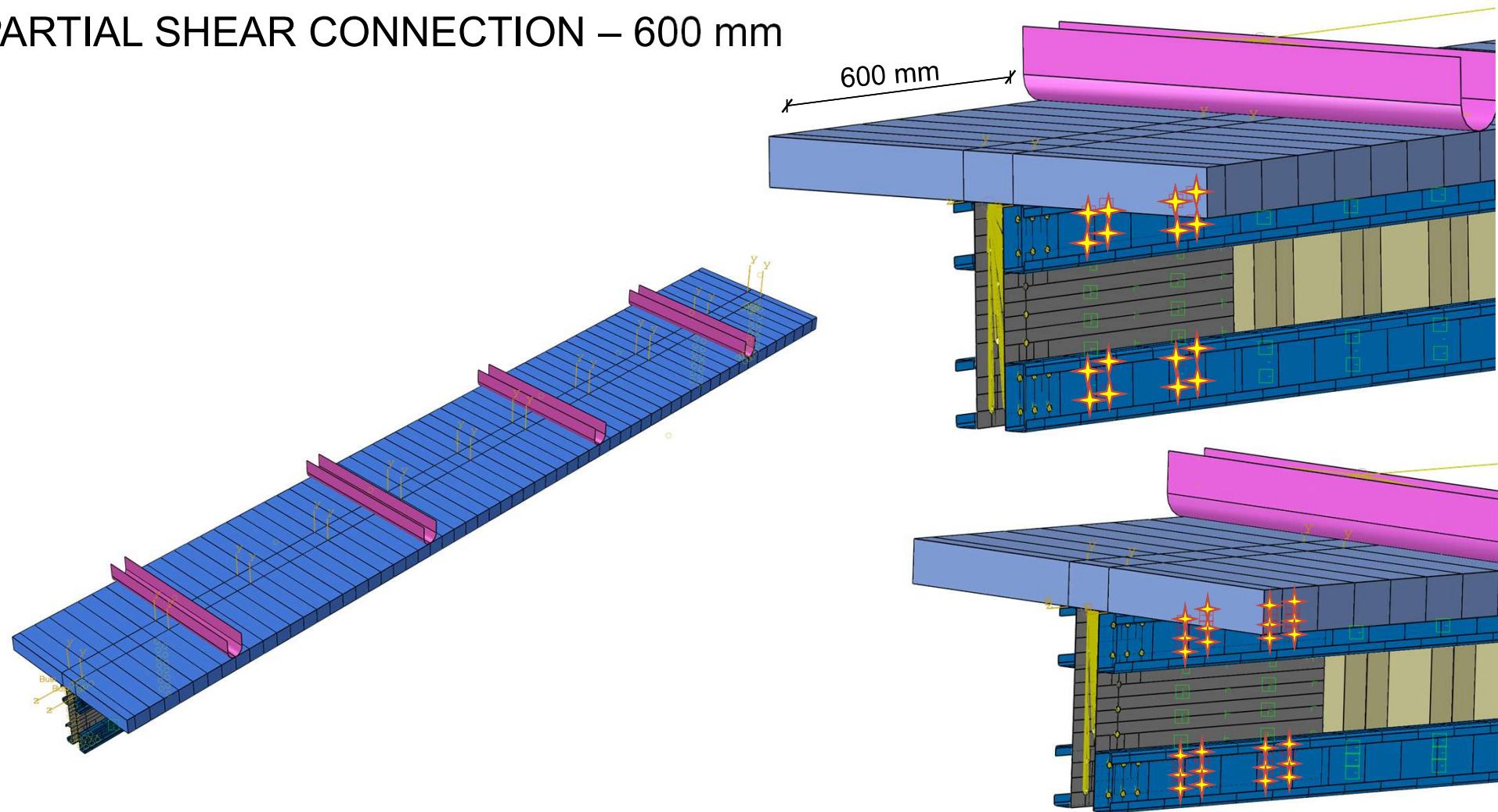

Analytical and numerical models

- Static system

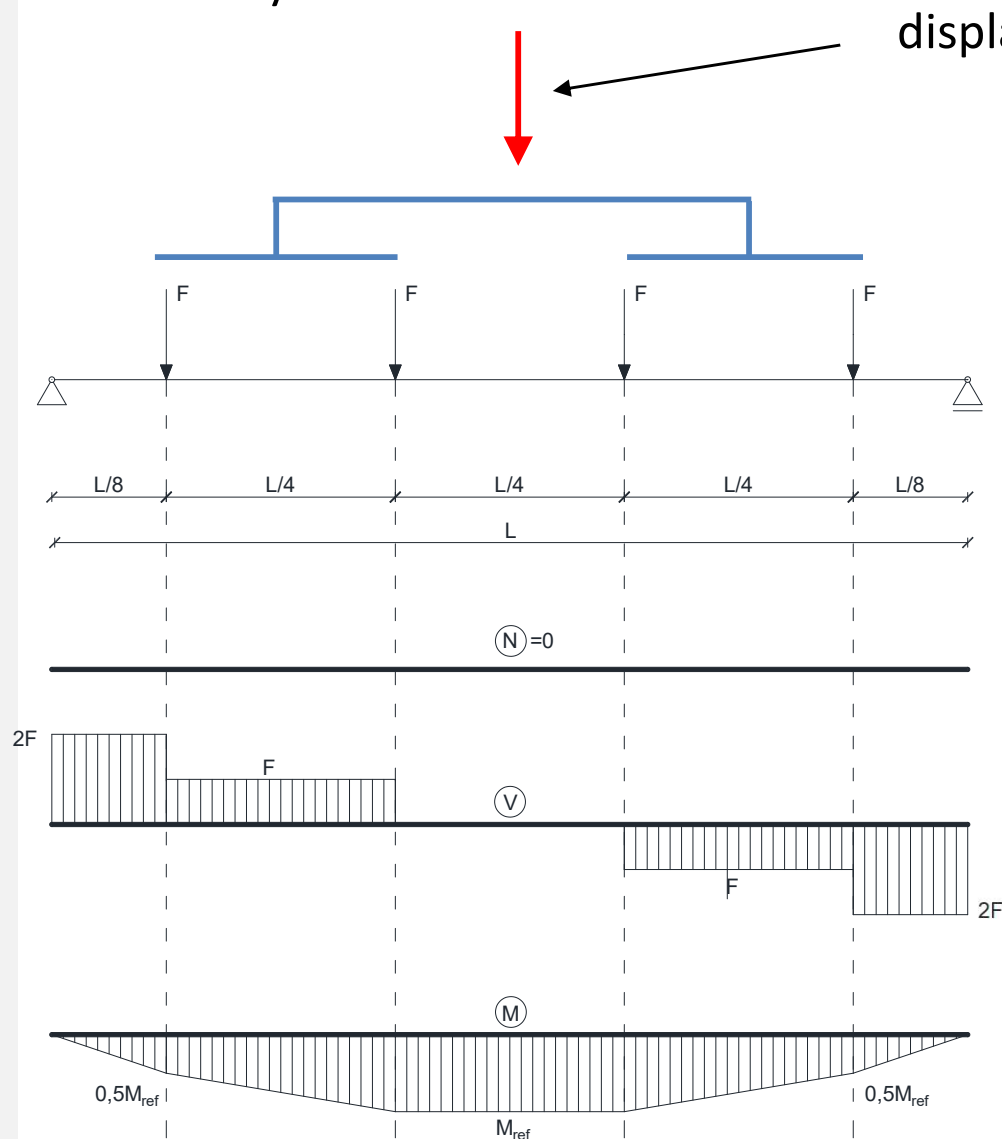

displacement

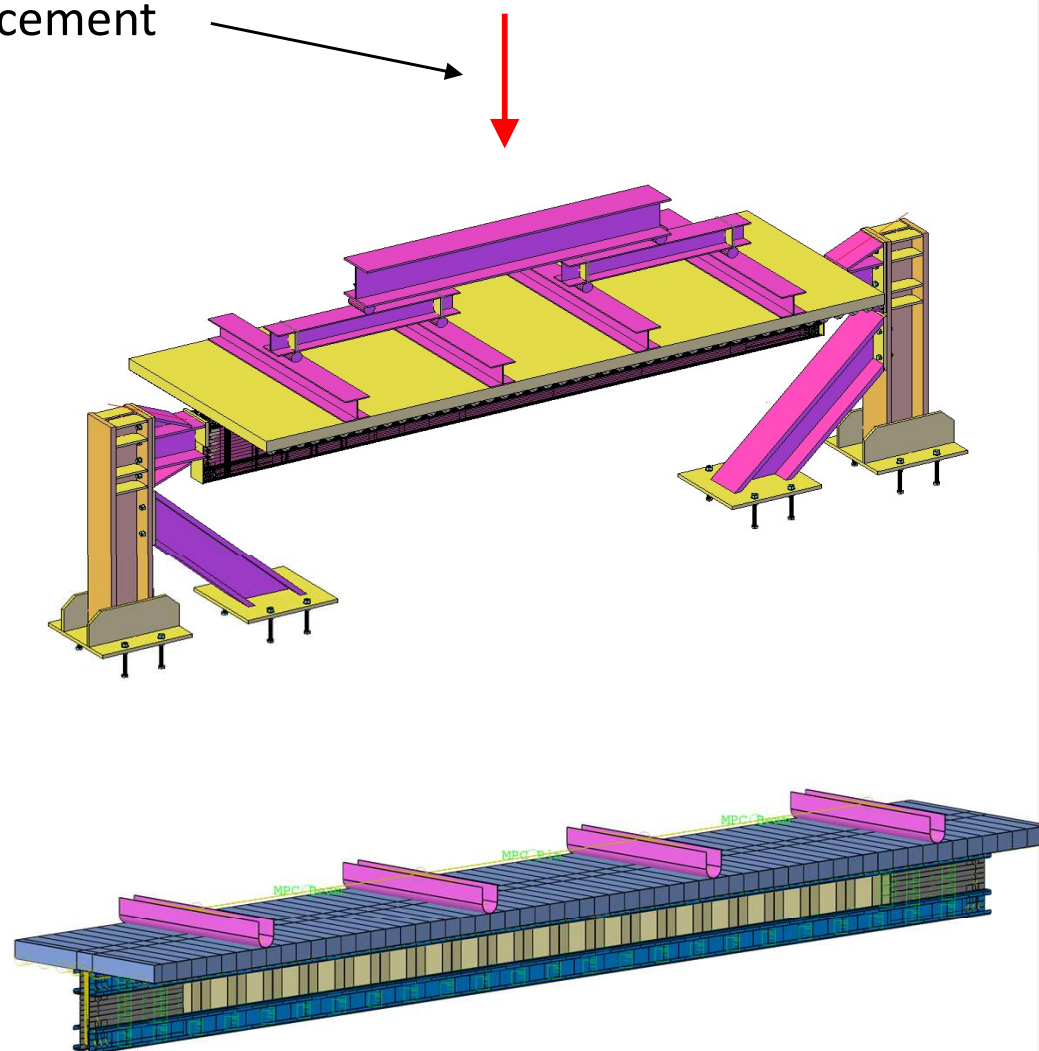

4. Analytical and numerical models

- Analytical Model – full/partial shear connection

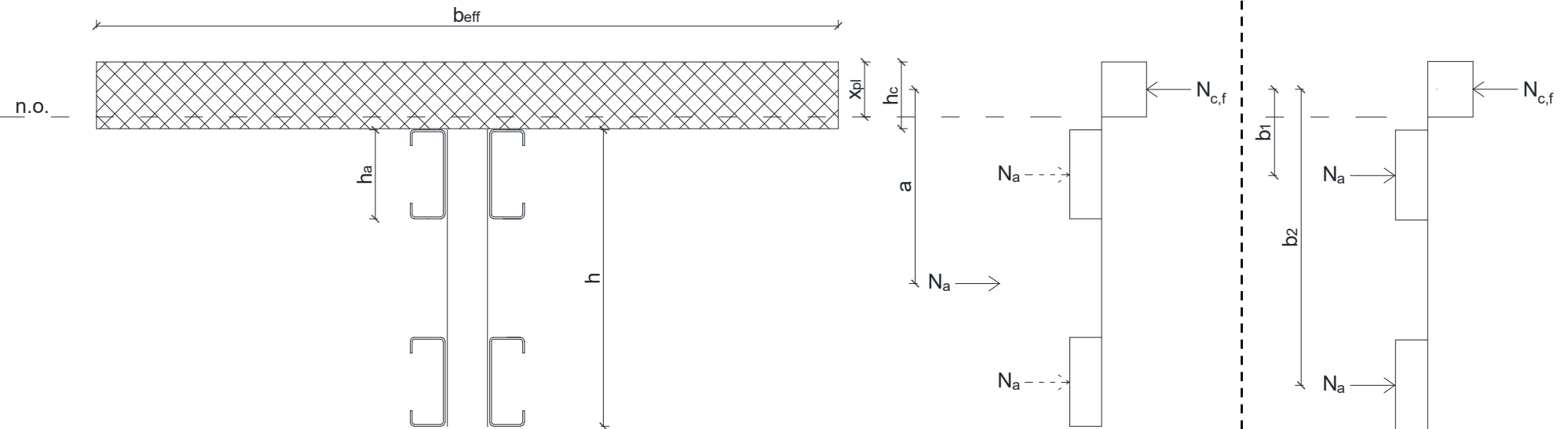

$$M_{pl,Rd} = N_{c,f} \cdot a$$

$$M_{pl,Rd} = b_{eff} \cdot x_{pl} \cdot 0,85 \cdot f_{cd} \cdot \left(\frac{h}{2} + h_c - \frac{x_{pl}}{2} \right)$$

$$M_{pl,Rd} = 2 \cdot A_a \cdot f_{yd} \cdot b_1 + 2 \cdot A_a \cdot f_{yd} \cdot b_2$$

$$M_{pl,Rd} = 2 \cdot A_a \cdot f_{yd} \cdot \left(\frac{h_a}{2} + h_c - \frac{x_{pl}}{2} \right) + 2 \cdot A_a \cdot f_{yd} \cdot \left(h - \frac{h_a}{2} + h_c - \frac{x_{pl}}{2} \right)$$

$$M_{pl,Rd} = M_{el,a,Rd} + (M_{pl,Rd} - M_{el,a,Rd}) \cdot \eta$$

$$\eta = \frac{n \cdot \gamma_c \cdot 2 \cdot P_{Rd,min}}{b_{eff} \cdot 0,85 \cdot f_{ck} \cdot x_{pl}}$$

- steel profiles: C120
- beam flange: C25/30

$b_{eff} = 1 \text{ m}$
 $h_c = 90 \text{ mm}$

5. Results and discussion

- TIE:

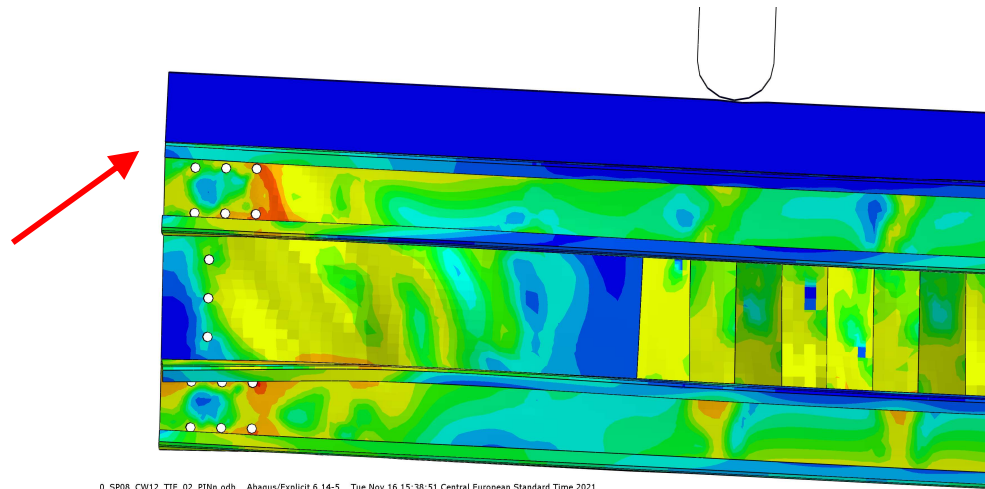

- w300:

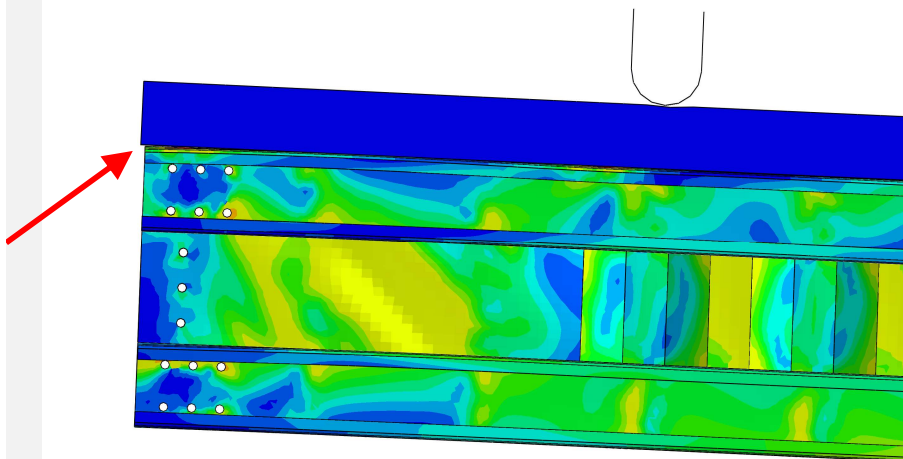

- w600:

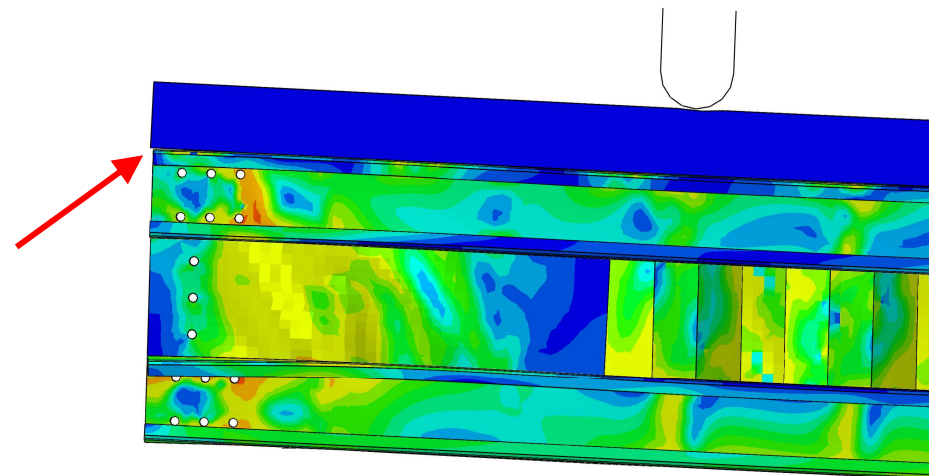

5. Results and discussion

- TIE SW2:

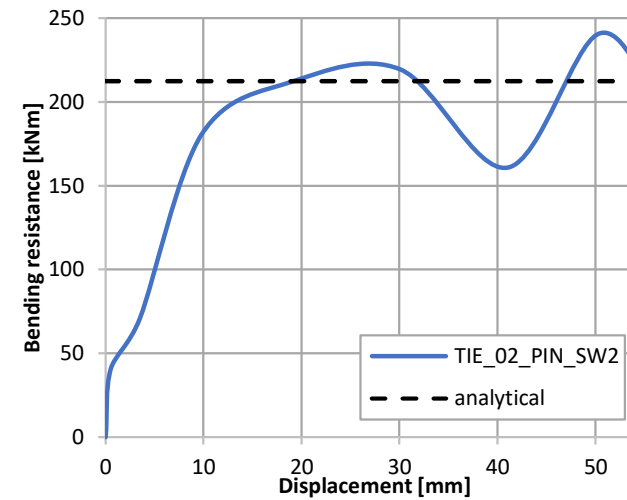
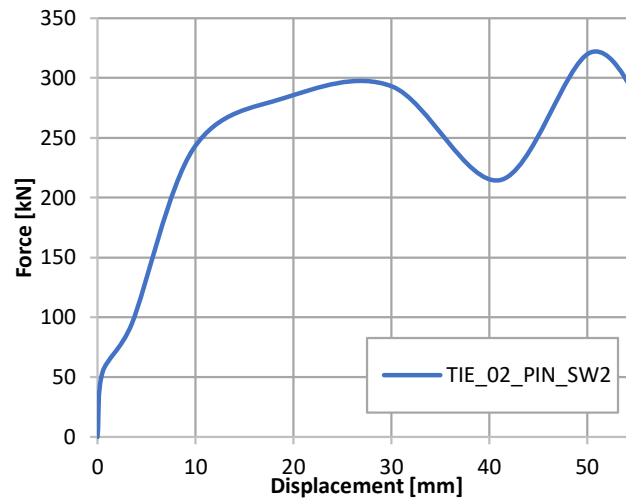

- TIE SW3:

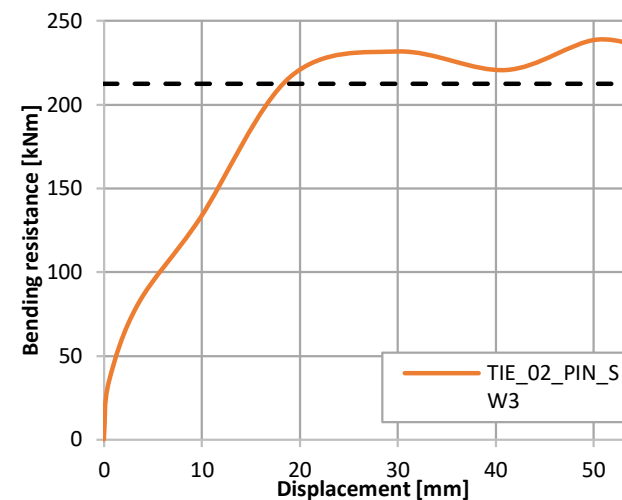
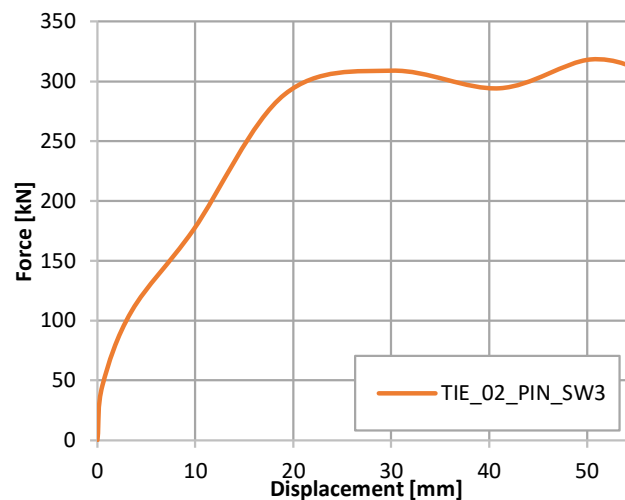

5. Results and discussion

TIE SW2

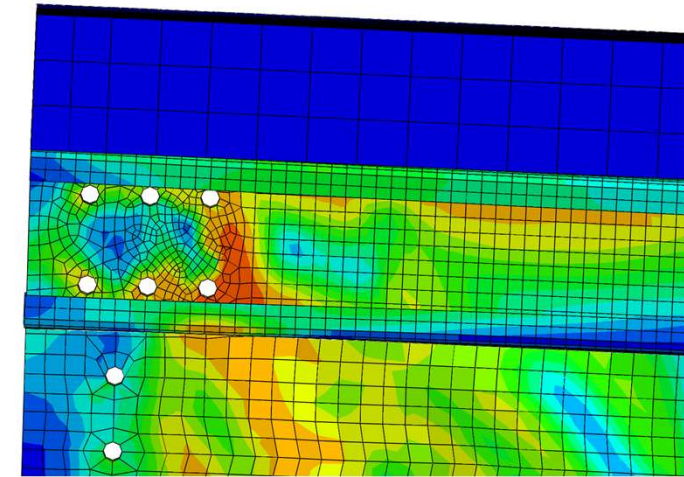
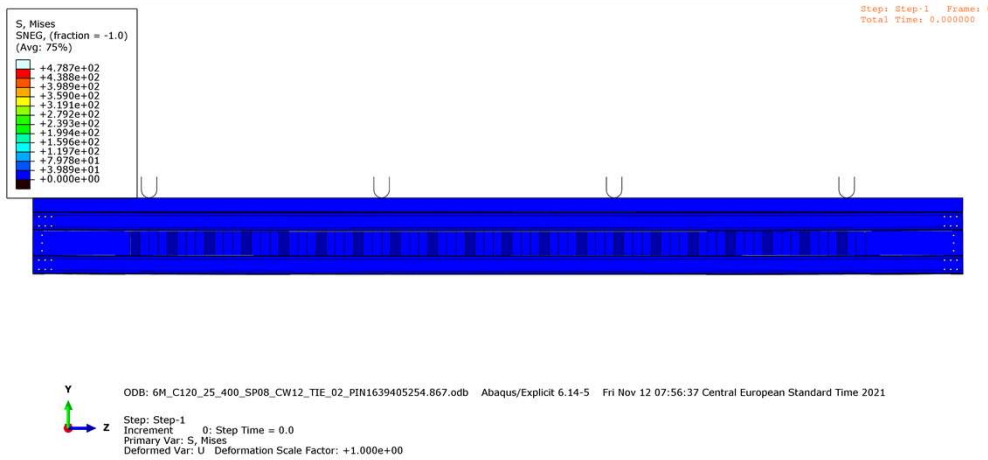

TIE SW3

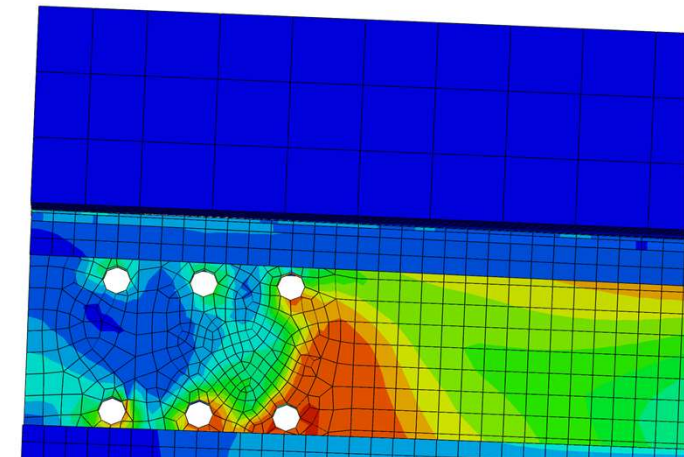
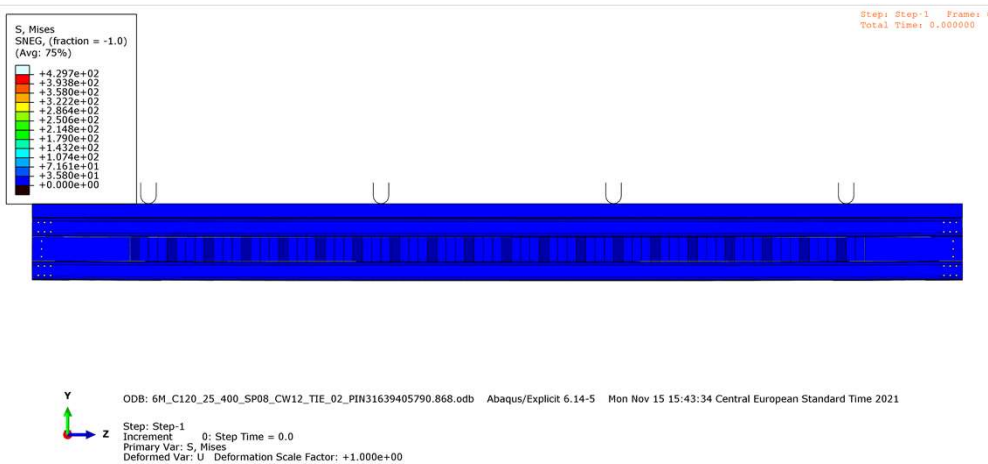

5. Results and discussion

- w300 SW2:

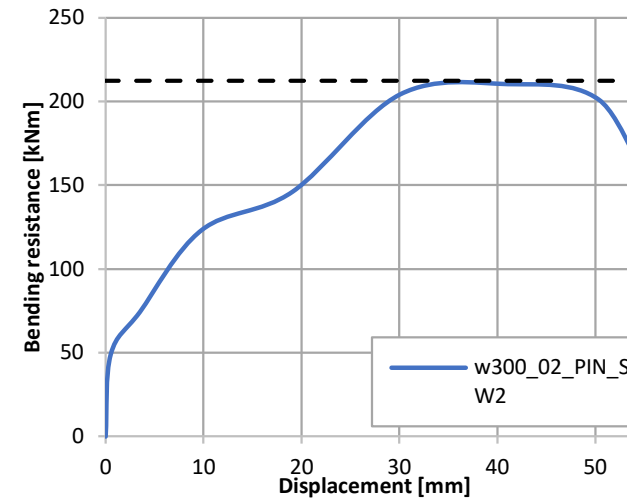
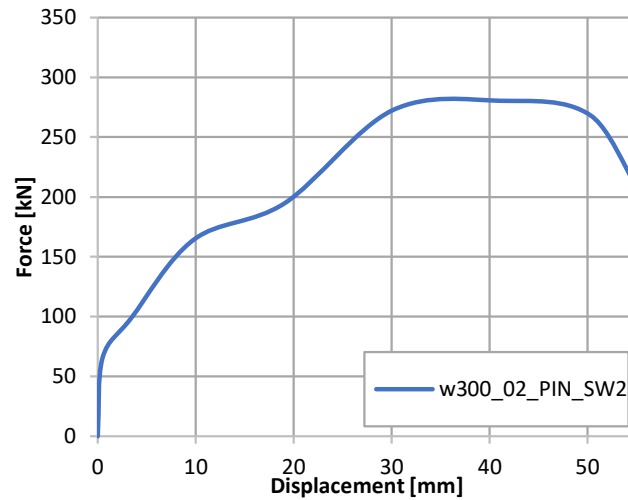

- w300 SW3:

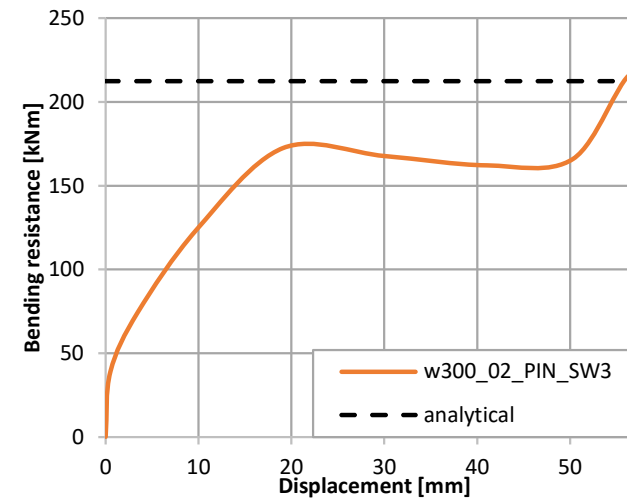
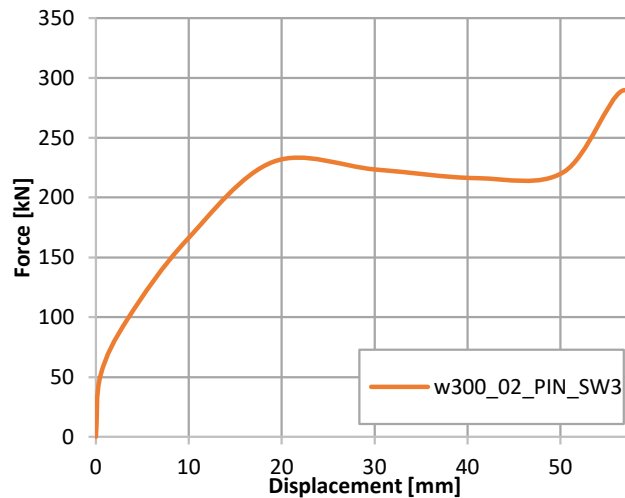

5. Results and discussion

w300 SW2

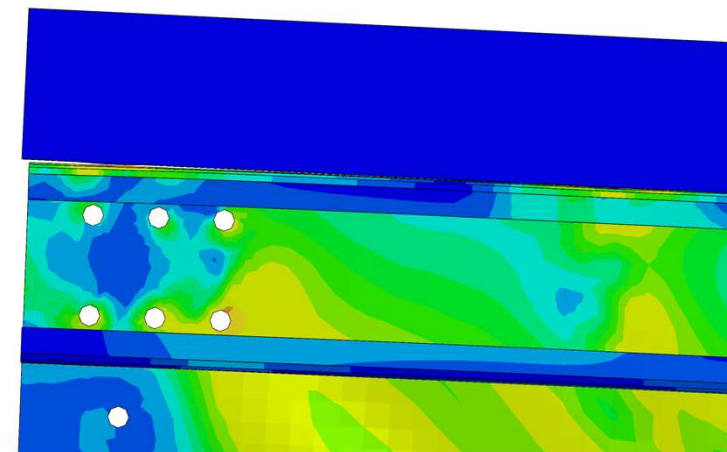
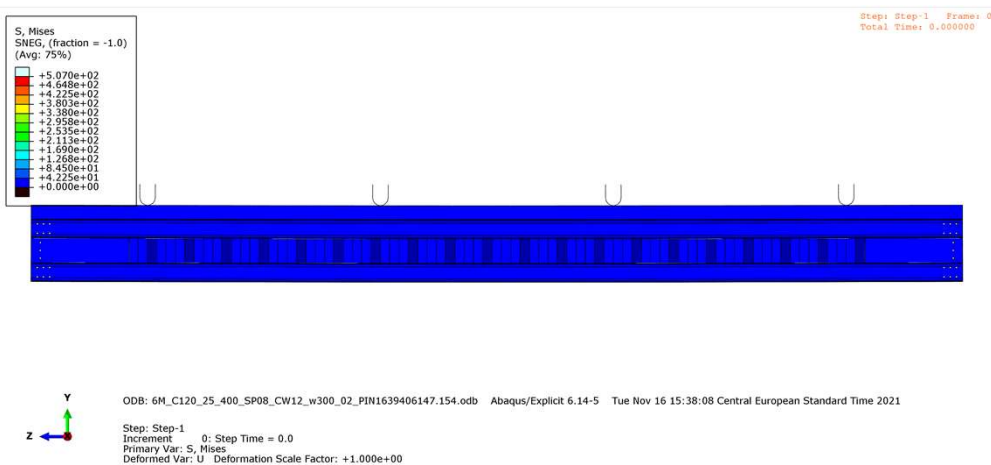

w300 SW3

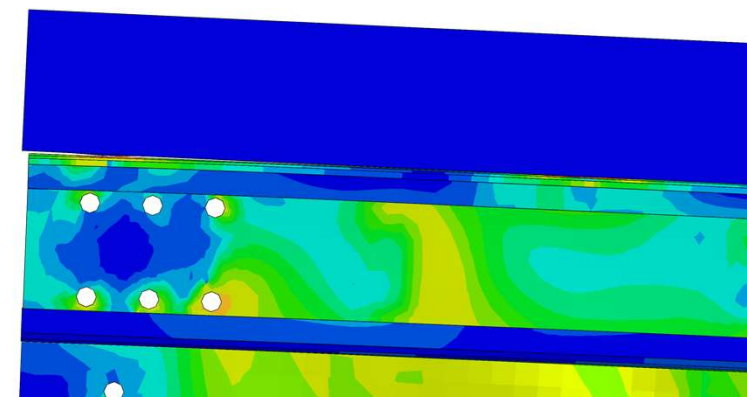
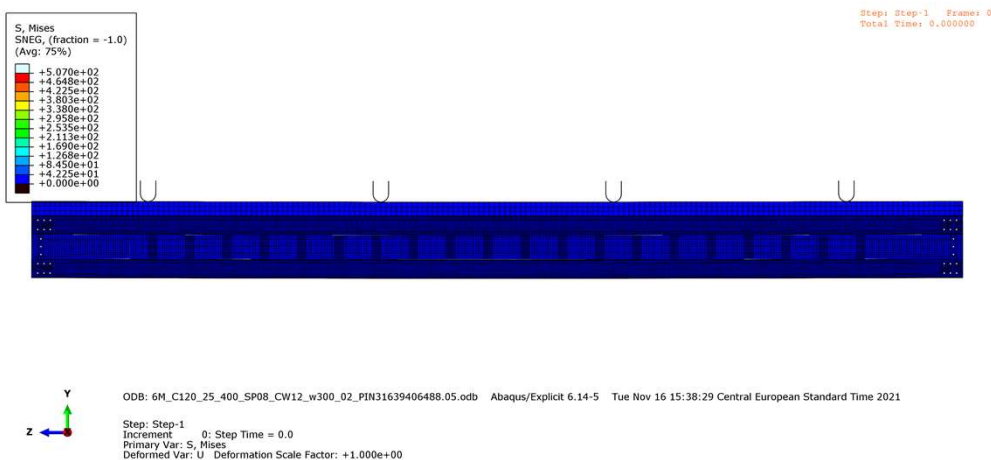

5. Results and discussion

- w600 SW2:

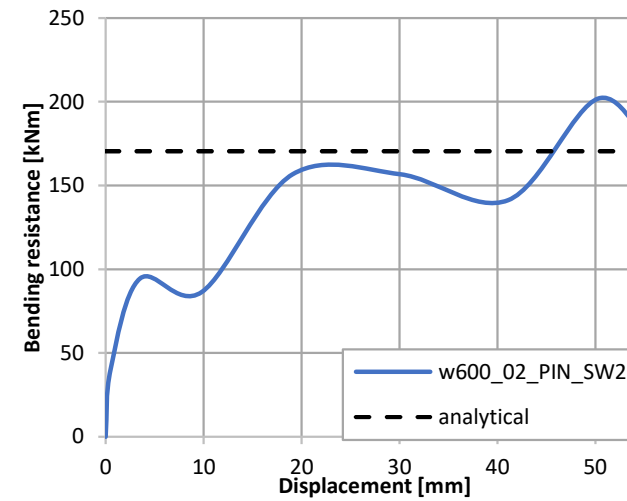
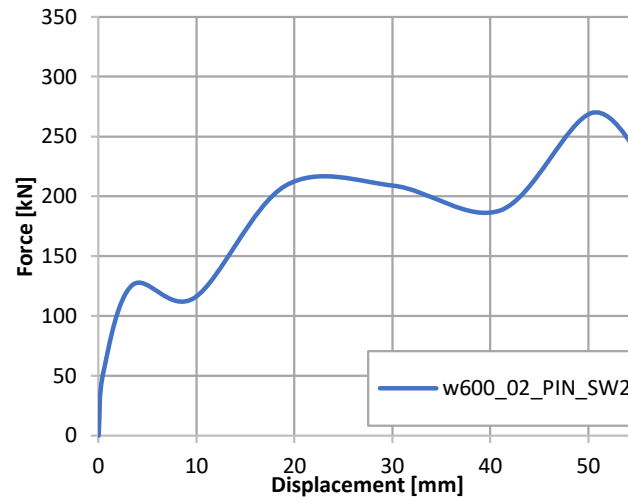

- w600 SW3:

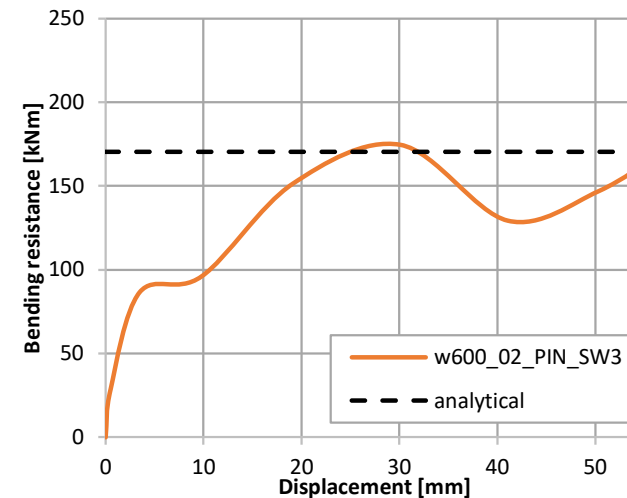
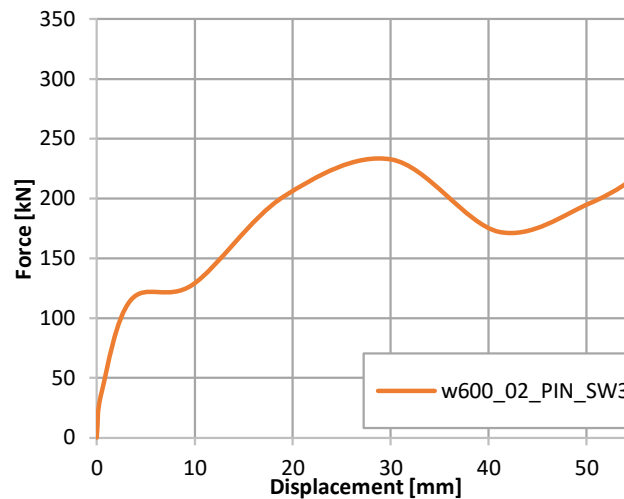

5. Results and discussion

w600 SW2

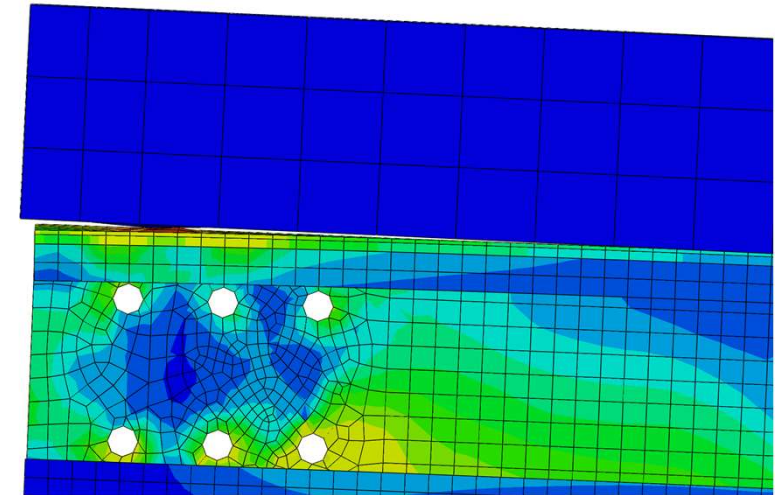
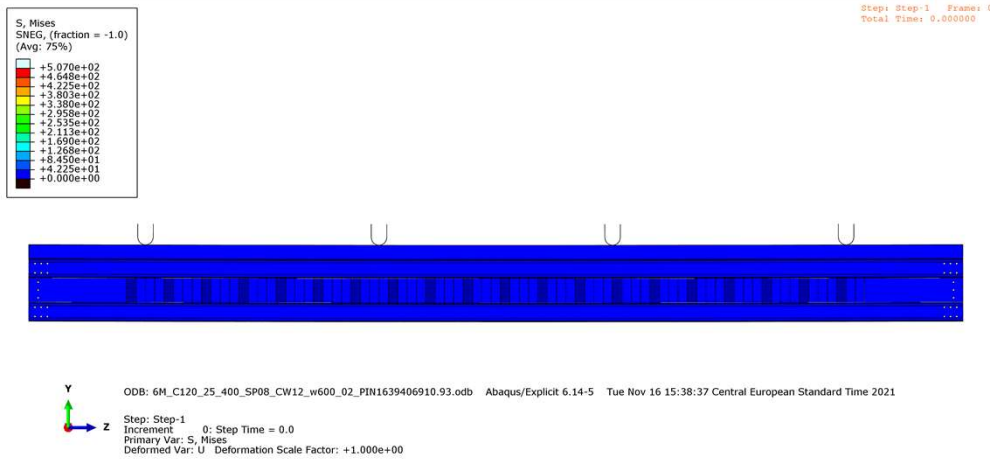

w600 SW3

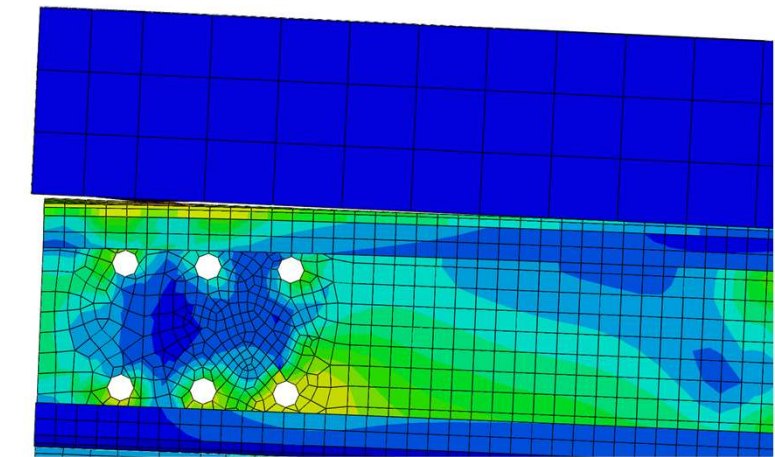
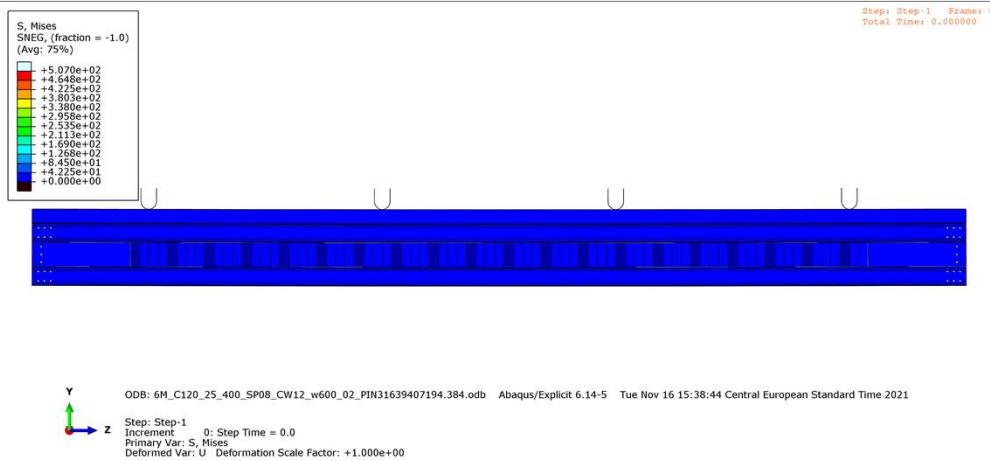

5. Results and discussion

- Comparison of the results

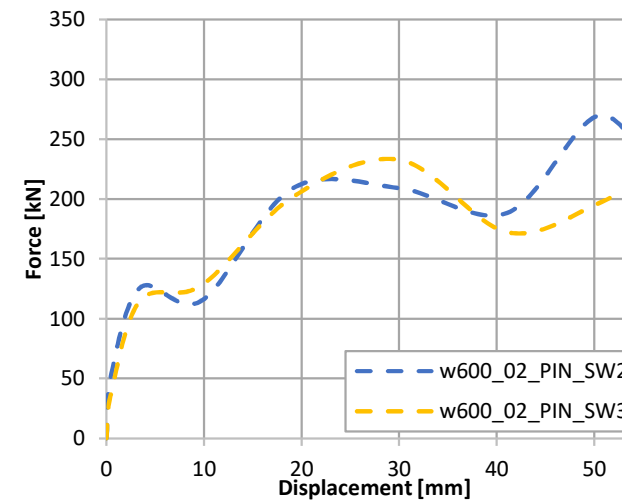
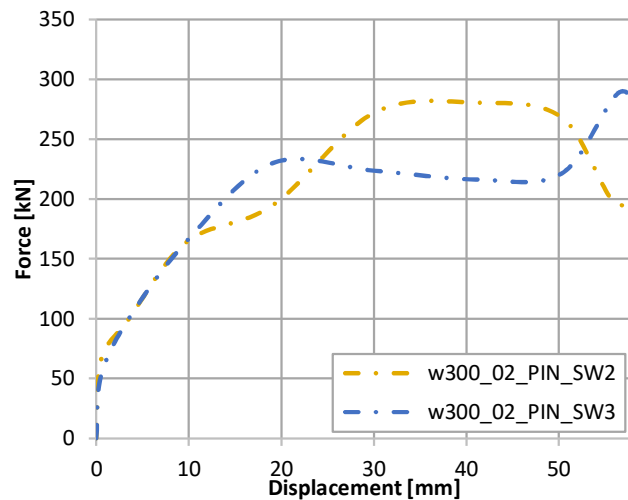
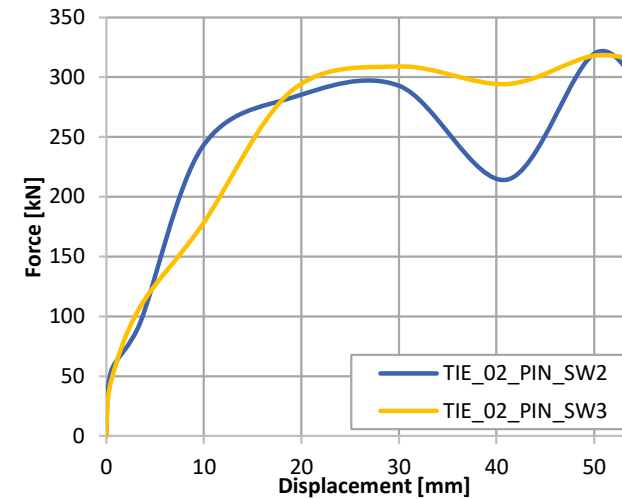
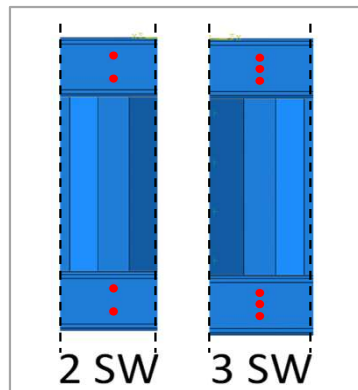

6. Conclusions

- Steel-concrete structural systems are, due to their efficiency, increasingly used in the construction industry and are the subject of intensive research.
- The system offers vital benefits in terms of a high degree of prefabrication, reusability and long spanning capability to maximize the values of building components and materials.
- bending capacity of the LWT-FLOOR beams is affected by the resistance of the cold-formed steel components, as well as by degree of shear connection.

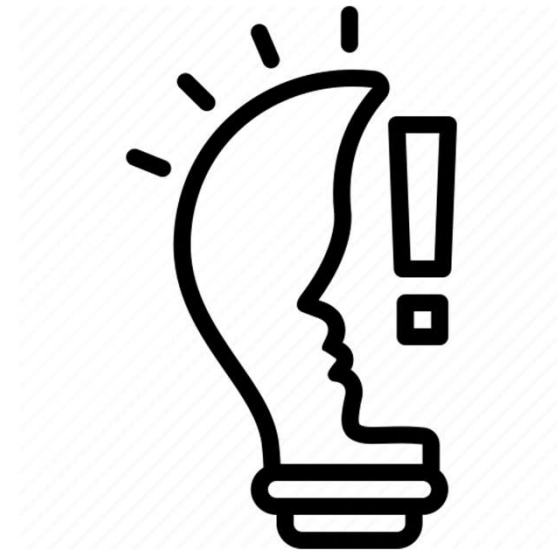

Project title: Innovative lightweight cold-formed steel-concrete composite floor system

Acronym: LWT-FLOOR Project ID: UIP-2020-02-2964

1st LWT-FLOOR Workshop

Numerical Analysis of Lightweight Cold-Formed Steel-Concrete Composite Floor System

Andrea Rajić, Vlaho Žuvelek

andrea.rajic@grad.unizg.hr

vlaho.zuvelek@grad.unizg.hr

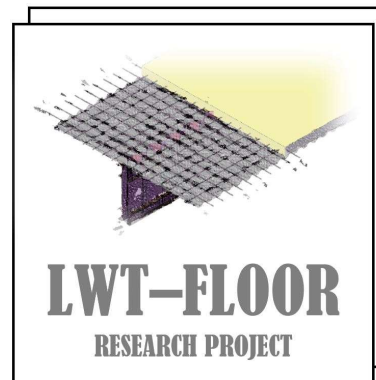

University of Zagreb/Faculty of Civil Engineering

<http://www.grad.unizg.hr/lwtfloor>